

INTO THE GREAT WIDE OPEN



C SEED HYDE 125

At the touch of a smartphone or tablet screen button, the C SEED Hyde 125 loudspeakers rise out of the ground, providing superior sound to round off perfect days, complement beautiful surroundings and entertain guests at garden parties.

The C SEED Hyde 125 loudspeakers are the last word in open-air sound brilliance - a system of passive speakers for configurations ranging from 2.0 stereo to 9.1 surround.

L-Acoustics passive speaker technology reproduces the entire frequency range with amazing and powerful brilliance. Each speaker projects a 110 degree beam angle, enabling the system to cover even large scale terraces while providing a thoroughly solid, stable sound experience.

THE ART OF SOUND



Vienna State Opera - powered by L-Acoustics

Projecting sound is an art in itself, and sounding great in open air environments takes an extra amount of genius. The heart of the C SEED Hyde 125 was created by masters of outdoor engineering: L-Acoustics was the obvious technology partner of choice when C SEED set out to create the world's best sounding retractable open air speaker system.

L-Acoustics earned their global fame by bringing superior sound to fabulous festivals, opera arenas, Broadway productions and memorable mega-events like Olympic Games opening ceremonies or Superbowl shows.

L-ACOUSTICS TECHNOLOGIES

In its over thirty years of research and development, L-Acoustics engineers have developed a number of major technologies in Acoustics, Mechanical Engineering, Amplification and Control. These innovations contribute to better, more predictable performance, increased flexibility in sound design and faster setup.



COAXIAL TECHNOLOGY

L-Acoustics introduced the first coaxial loudspeaker enclosure for professional sound reinforcement, bringing studio quality to near-field applications for the first time. Since then, coaxial technology has been implemented in all L-Acoustics point sources and constitutes the heart of the X Series.



LAMINAR VENTING

All current L-Acoustics loudspeaker enclosures with low-range capacities feature laminar vents which provide high SPL while eliminating turbulence noise.



POINT SOURCE

The point source's wide, conical directivity pattern imparts excellent spatialization and no minimum listening distance, assuring a flawless listening experience when monitoring sound.

UNIQUE SOUND INNOVATION

The name C SEED Hyde 125 refers to the peak speaker power, expressed in "decibel sound pressure", the professional audio industry's internationally accepted measure of sonic performance.

Does this sound a bit abstract? Well, 125 decibels translate, for all practical purposes, into "loud enough for anything one will ever want to hear". As a matter of fact, this is the sound pressure experienced by the audience of an opera house concert.

It is therefore a safe assumption that the C SEED Hyde 125 has sufficient power reserves to entertain even seriously partying capacity crowds by the poolside. On the other hand, it is worth noting that even at

very conservative volumes, the system is capable of unparalleled sound projection at angles wide enough to cover large terraces and gardens.

These are genuine high-end speakers, built to faithfully reproduce every last nuance of a beautiful violin solo or the rich texture of a great movie soundtrack, even on windy days. For massive performance they are built into one-piece metal casings, precision-machined out of massive blocks of aluminum. This provides the ultimate resonating body which makes the most of every single note, from delicate piano passages to screaming guitar riffs.

FROM DEEP DOWN

C SEED SUB 136

The acoustic impact of the C SEED Sub matches the visual attraction of its minimalistic design. This sub packs a high excursion driver, ultra-low vibration walls and laminar airflow L-vents in dramatically reduced port noise, maximized dynamics and power handling for an exceptional level of performance.

Even smallest technical details breathe the passion to capture feelings even in the lowest recordable frequencies. Indeed, the frequency band of the C SEED Sub starts far below the lowest frequency discernible for the human ear, where sound is not audible any more, yet physically felt.



ALL THE MAGIC AT YOUR FINGERTIPS' COMMAND

The C SEED Audio app gives you full control over your outdoor music experience.

Download it free of charge from the App Store to control kinematic functions, music choice, volume, loudness, balance, treble and bass. Or take the shortcut to perfection, selecting the app's presets for dozens of genres and moods, fine-tuned for your pleasure by the world's leading sound engineers.



C SEED SUPERMARINE SPEAKERS



00:03 ☹



00:10 ☹



00:20 ☹

The most powerful sound experience

Hidden in underfloor storage casings, the C SEED Supermarine speakers await activation. At the push of a button on the C SEED Audio app they rise majestically to face the audience, and the stage is set for an unforgettable performance. Visually, they complement the C SEED Supermarine TV monolith style. Acoustically, they are providing superior sound to round off perfect days, grace beautiful surroundings and entertain guests at superyacht parties.

Ultimate quality

One-piece metal casings, precision-machined out of massive blocks of aluminium, provide C SEED Supermarine speakers with superior resonating bodies for overwhelming sound quality. Stainless steel parts in critical spots guarantee reliable longevity.

Concert acoustic from any angle

The heart of the C SEED 125 was created by masters of outdoor speaker engineering: L-Acoustic's passive speaker technology reproduces the entire frequency range with amazing, powerful brilliance.

Each speaker projects a 110 degree beam angle, enabling the system to cover even super large decks while providing a remarkably stable sound experience.

Select your size

C SEED Supermarine speaker system is available in two sizes: a standard version of 89 cm height and a smaller version of 48 cm height to accommodate to the available space for the necessary storage casing.

FEATURES SPEAKERS HYDE 125 / SUB 136

SPEAKER SYSTEM	C SEED HYDE 125
Type:	Retractable passive 2-way coaxial outdoor speaker system
Configuration:	Full range from 2.0 stereo to 9.2 surround sound
Speaker type:	L-Acoustics coaxial
Axisymmetric maximum:	125 dB
Nominal directivity (-6dB):	100°
Usable bandwidth: (-10dB):	60Hz-20kHz
Physical data H x W x D:	890 x 332 x 332 mm / 35 x 13 x 13 inch
Weight:	140 kg / 308 lbs
Integrated light:	RGB illuminated C SEED Logo and top edge
Extend/retract drive:	Remote-controlled electric telescopic drive
Remote control:	APP controlled IOS, intelligent embedded audio control

Option colors	Cabinets available in black or white other colors, finishes and coatings on request
Flush mount:	This option allows seamless integration into surfaces made of stone, wood, tile or concrete

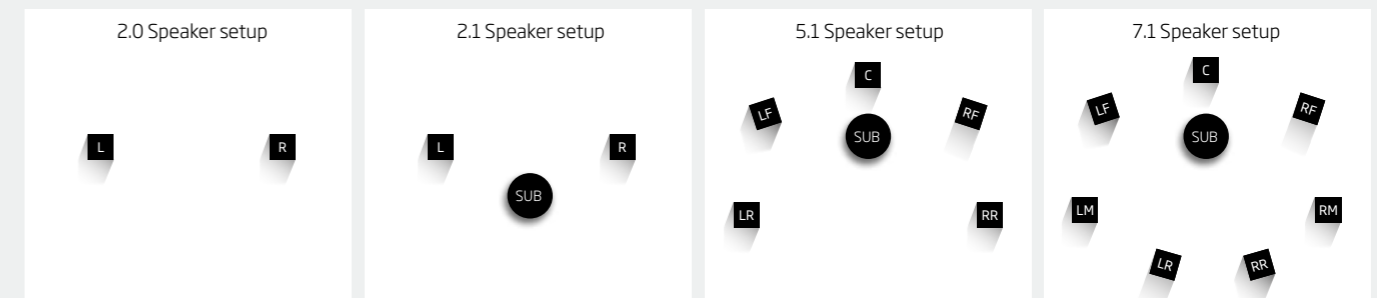
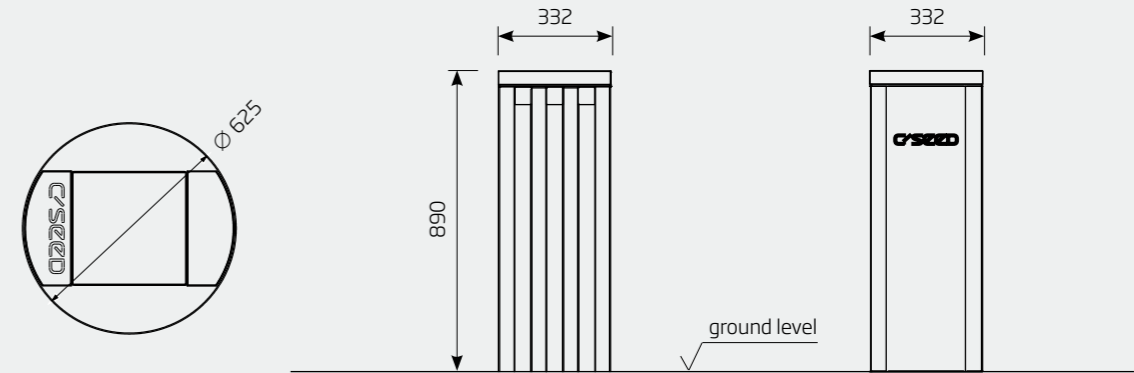

SPEAKER SYSTEM	C SEED SUB 136
Type:	Retractable passive outdoor subwoofer system
Configuration:	Full range from 2.0 stereo to 9.2 surround sound
Speaker type:	L-Acoustics coaxial
Maximum SPL:	136 dB
Low frequency limit (-10dB):	32 Hz
Physical data dia:	380 x 572 x 572 mm / 15 x 22.5 x 22.5 inch
Weight:	185 kg / 410 lbs
Extend/retract drive:	Remote-controlled electric telescopic drive
RMS handling capability:	600 W
LF:	L-Acoustics 15" weather resistant, 8 ohms
Remote control:	APP controlled IOS, intelligent embedded audio control

Option colors	Cabinets available in black or white other colors, finishes and coatings on request
Flush mount:	This option allows seamless integration into surfaces made of stone, wood, tile or concrete

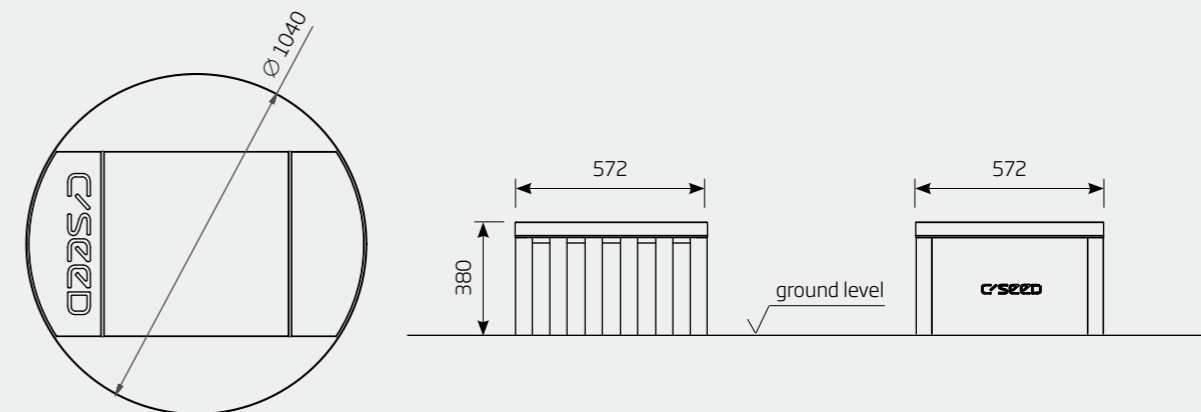

FEATURES

SUPERMARINE SPEAKERS

125 - 89 / 48

SPEAKER SYSTEM	
C SEED 125 SUPERMARINE / 89	
Type:	Retractable passive 2-way coaxial outdoor speaker system
Configuration:	Full range from 2.0 stereo to 9.2 surround sound
Speaker type:	L-Acoustics coaxial
Axisymmetric maximum:	125 dB
Nominal directivity (-6dB):	100°
Usable bandwidth: (-10dB):	60Hz-20kHz
Physical data H x W x D:	890 x 332 x 332 mm / 35 x 13 x 13 inch
Weight:	150 kg / 331 lbs
Materials:	Marine Grade Stainless Steel, Aluminium & rubber gasket
Integrated light:	RGB illuminated top edge
Extend/retract drive:	Remote-controlled electric telescopic drive
Remote control:	APP controlled IOS, intelligent embedded audio control
Option colors	
	Cabinets available in black or white other colors, finishes and coatings on request
Flush mount:	This option allows seamless integration into surfaces made of stone, wood, tile or concrete.

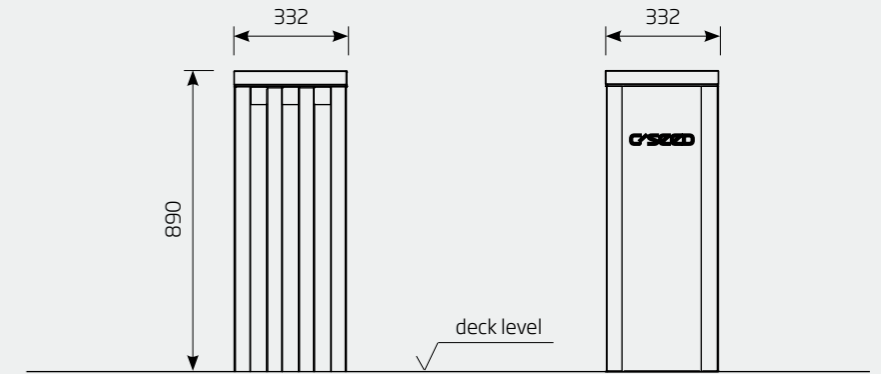
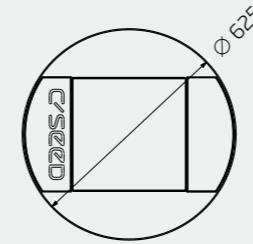

SPEAKER SYSTEM	
C SEED 125 SUPERMARINE / 48	
Type:	Retractable passive 2-way coaxial outdoor speaker system
Configuration:	Full range from 2.0 stereo to 9.2 surround sound
Speaker type:	L-Acoustics coaxial
Axisymmetric maximum:	125 dB
Nominal directivity (-6dB):	100°
Usable bandwidth: (-10dB):	60Hz-20kHz
Physical data H x W x D:	482 x 332 x 332mm / 19 x 13 x 13 inch
Weight:	110 kg / 243 lbs
Materials:	Marine Grade Stainless Steel, Aluminium & rubber gasket
Integrated light:	RGB illuminated top edge
Extend/retract drive:	Remote-controlled electric telescopic drive
Remote control:	APP controlled IOS, intelligent embedded audio control
Option colors	
	Cabinets available in black or white other colors, finishes and coatings on request
Flush mount:	This option allows seamless integration into surfaces made of stone, wood, tile or concrete.

